

# ACCESSORIES

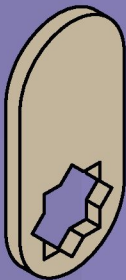





**WOODEN**  
FURNITURE LOCKS



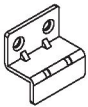
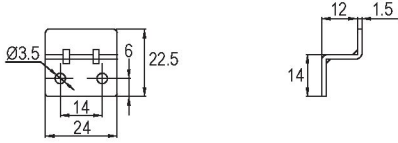
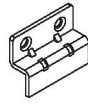
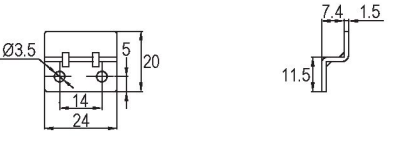

CODE	MATERIAL	FINISH	FOR USE WITH	DIMENSION (mm)	
รหัส	วัสดุ	สี	ใช้งานร่วมกับ	ขนาด(มม.)	
DK040	SPCC	01 NICKEL	A-611, A-711		
DK041	SPCC	01 NICKEL	A-601, A-701, A-601SA, A-614, A-714, A-616, A-716, A-648, A-748, A-649, A-749, A-731, A-750, A-608, A-708, A-652, A-752, A-615, A-715, A-623		
DK047	SPCC	01 NICKEL	A-611, A-711		
DK075	SPCC	01 NICKEL	A-619, A-620		
DK100	SPCC	01 NICKEL	A-612, A-712, A-731, A-760, A-761		
DK101	SPCC	15 WHITE ZINC	A-602, A-702, A-603, A-703, A-608, A-708, A-653		
DK159	SPCC	01 NICKEL	A-611, A-711		
DK179	SPCC	01 NICKEL	A-629		
DK180	SPCC	01 NICKEL	A-628		

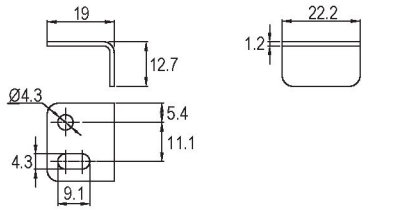
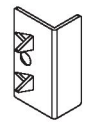
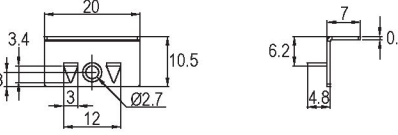
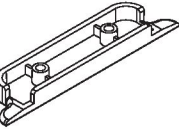
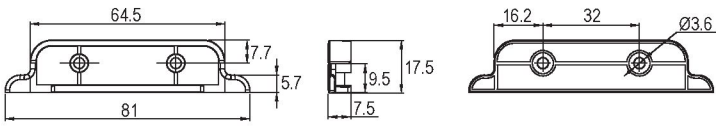
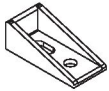
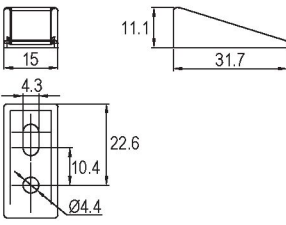

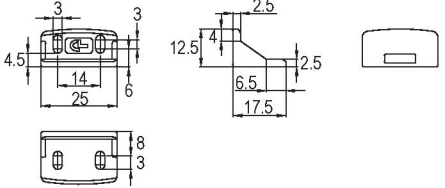
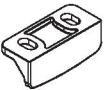
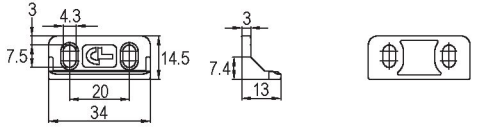
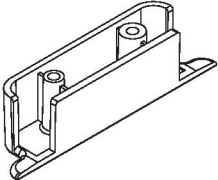
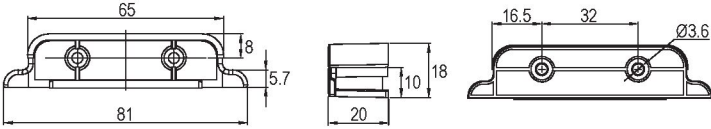
CODE รหัส	MATERIAL วัสดุ	FINISH สี	FOR USE WITH ใช้งานร่วมกับ	DIMENSION (mm) ขนาด (มม.)
<b>DK196</b> 	SPCC	01 NICKEL	A-628	
<b>DK198</b> 	SPCC	01 NICKEL	A-627	
<b>DK261</b> 	SPCC	15 WHITE ZINC	A-602, A-702, A-603, A-703, A-653, A-758H-TYPE C, A-758H-TYPE D	
<b>DK498</b> 	SPCC	01 NICKEL	VT003	
<b>R155</b> 	ABS	91 BLACK	A-636H, A-736H, A-636V, A-736V	
<b>R187</b> 	PP	91 BLACK	A-602, A-702, A-603, A-703, A-653	
<b>R202</b> 	PP	71 WHITE	A-765	
<b>R240</b> 	PA66	65 BROWN	D-107, D-108	
<b>R256</b> 	ABS	91 BLACK	A-636H, A-736H, A-636V, A-736V	











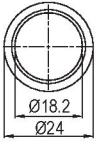
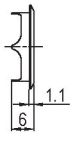

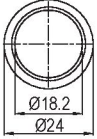
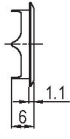

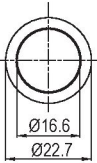
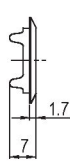

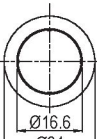

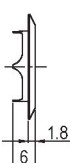

CODE รหัส	MATERIAL วัสดุ	FINISH สี	FOR USE WITH ใช้งานร่วมกับ	DIMENSION (mm) ขนาด (มม.)
DK001	SPCC	01 NICKEL	A-601, A-701	
DK005	SPCC	01 NICKEL	A-611, A-711	
DK025	SPCC	01 NICKEL	A-611, A-711 A-615, A-715	
DK102	SPCC	01 NICKEL	A-605, A-705	
DK175	SPCC	04 BLACK E.D.P.	A-637, A-737	
DK190	SPCC	01 NICKEL	A-611, A-711	
DK191	SPCC	01 NICKEL	A-611, A-711	
DK209	SPCC	15 WHITE ZINC	A-664, A-764	
DK238	SPCC	01 NICKEL	A-607	

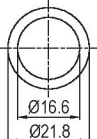

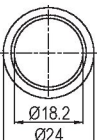
CODE รหัส	MATERIAL วัสดุ	FINISH สี	FOR USE WITH ใช้งานร่วมกับ	DIMENSION (mm) ขนาด(มม.)
DK416	SPCC	01 NICKEL	SECURITE CUPBOARD LOCK	
DK420	SPCC	01 NICKEL	SECURITE DRAWER LOCK	
DK458	SPCC	16 RAINBOW ZINC	VT001	
DK479	SUS	00 RAW MATERIAL		
DK503	SPCC	01 NICKEL	A-646V	

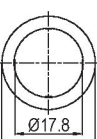

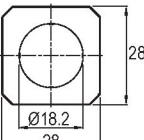
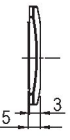
CODE รหัส	MATERIAL วัสดุ	FINISH สี	FOR USE WITH ใช้งานร่วมกับ	DIMENSION (mm) ขนาด(มม.)	
<b>F001</b> 	SPCC	01 NICKEL	18mm CYLINDER HOUSING DIAMETER		
<b>F001 (SUS304)</b> 	SUS304	00 RAW MATERIAL	18mm CYLINDER HOUSING DIAMETER		
<b>F002</b> 	SPCC	01 NICKEL	16.5mm CYLINDER HOUSING DIAMETER		
<b>F006</b> 	SPCC	01 NICKEL	16.5mm FOR OVERSIZED DRILL HOLE		
<b>F013</b> 	SPCC	01 NICKEL	SUITABLE FOR FOR OVERSIZED DRILL HOLE		
<b>F016</b> 	SPCC	01 NICKEL	16.5mm CYLINDER HOUSING DIAMETER		
<b>F017</b> 	SPCC	01 NICKEL	18mm CYLINDER HOUSING DIAMETER		
<b>F018</b> 	SPCC	01 NICKEL	18mm CYLINDER HOUSING DIAMETER		
<b>F034</b> 	ZDA 3	05A BLACK 14 WHITE 28 SATIN - CHROME	18mm CYLINDER HOUSING DIAMETER		

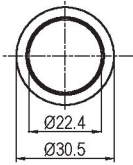
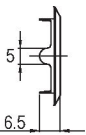

CODE	MATERIAL	FINISH	FOR USE WITH	DIMENSION (mm)	
รหัส	วัสดุ	สี	ใช้งานร่วมกับ	ขนาด (มม.)	
F019	SPCC	01 NICKEL	22mm CYLINDER HOUSING DIAMETER		











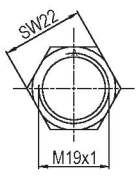
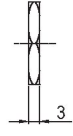

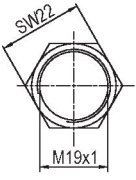
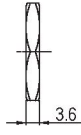
CODE รหัส	MATERIAL วัสดุ	FINISH สี	FOR USE WITH ใช้งานร่วมกับ	DIMENSION (mm) ขนาด (มม.)
F007	SPCC	15 WHITE ZINC	A-607, B-607	
F020	SPCC	15 WHITE ZINC	A-607, B-607	
F029	SPCC	15 WHITE ZINC	A-607, B-607	
F030	ABS	27 SATIN-NICKEL	D-107	
F031	ABS	27 SATIN-NICKEL	D-108	

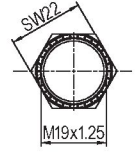
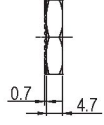

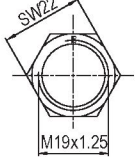
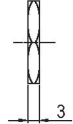

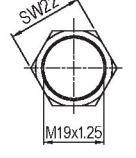
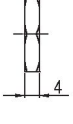
CODE รหัส	MATERIAL วัสดุ	FINISH สี	FOR USE WITH ใช้งานร่วมกับ	DIMENSION (mm) ขนาด(มม.)	
M006 	SPCC	15 WHITE ZINC	A-607, B-607		
M007 	BRASS	00 RAW MATERIAL	A-607, B-607		
M016 	ZDA 3	16 RAINBOW ZINC	A-607, B-607		
M024 	SPCC	16 RAINBOW ZINC	A-607, B-607		
M029 	ZDA 3	16 RAINBOW ZINC	A-607, B-607		



CODE รหัส	MATERIAL วัสดุ	FINISH สี	FOR USE WITH ใช้งานร่วมกับ	DIMENSION (mm) ขนาด (มม.)	
G002	ALUMINIUM	00 RAW MATERIAL	A-603, A-703		
				<p>STANDARD LENGTHS</p> <ul style="list-style-type: none"> <li>*L= 500 mm</li> <li>*L= 600 mm</li> <li>*L= 1000 mm</li> <li>*L= 1500 mm</li> </ul>	
G004	ALUMINIUM	00 RAW MATERIAL	A-603, A-703		
				<p>STANDARD LENGTHS</p> <ul style="list-style-type: none"> <li>*L= 500 mm</li> <li>*L= 600 mm</li> </ul>	
G017	ALUMINIUM	00 RAW MATERIAL	A-603, A-703		
				<p>STANDARD LENGTHS</p> <ul style="list-style-type: none"> <li>*L= 500 mm</li> <li>*L= 600 mm</li> </ul>	
G234	ALUMINIUM	00 RAW MATERIAL	A-603, A-703		
				<p>STANDARD LENGTHS</p> <ul style="list-style-type: none"> <li>*L= 500 mm</li> <li>*L= 600 mm</li> </ul>	
G275	ALUMINIUM	00 RAW MATERIAL	A-603, A-703		
				<p>STANDARD LENGTHS</p> <ul style="list-style-type: none"> <li>*L= 500 mm</li> <li>*L= 600 mm</li> </ul>	



CODE	MATERIAL	FINISH	FOR USE WITH	DIMENSION (mm)
รหัส	วัสดุ	สี	ใช้งานร่วมกับ	ขนาด (มม.)



ALUMINIUM

00 RAW MATERIAL

A-758H-TYPE C,  
A-758H-TYPE D

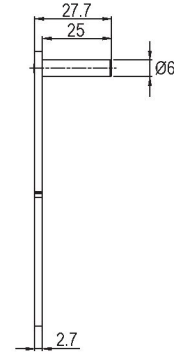





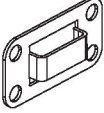
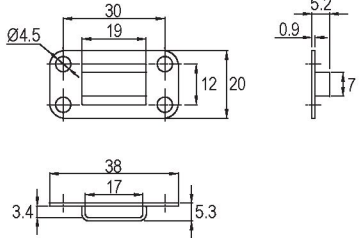
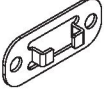
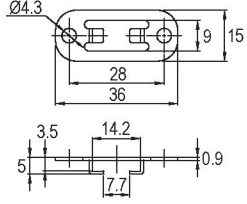
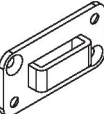
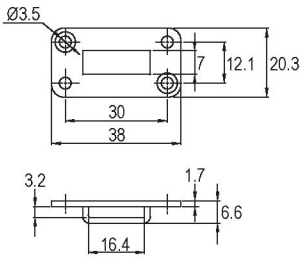



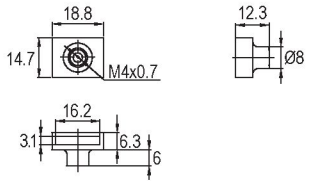

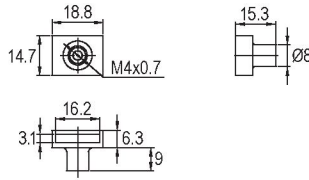

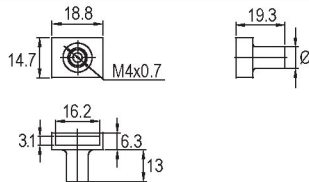

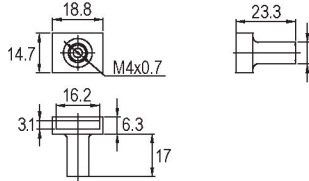

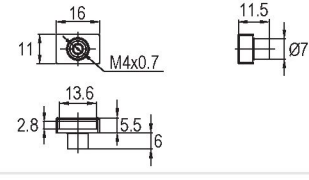
STANDARD LENGTHS
*L= 500 mm
*L= 600 mm
*L= 1000 mm
*L= 1500 mm

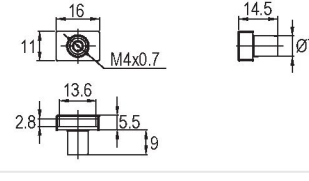

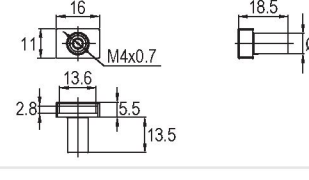

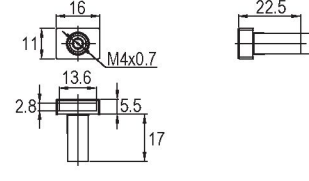

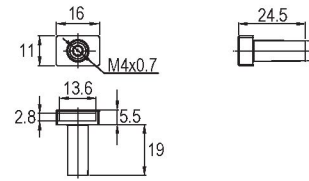



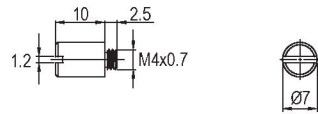
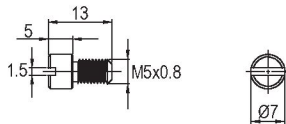

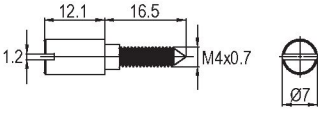
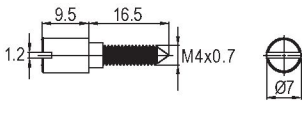
CODE รหัส	MATERIAL วัสดุ	FINISH สี	FOR USE WITH ใช้งานร่วมกับ	DIMENSION (mm) ขนาด (มม.)
<b>DK021</b> 	SPCC	16 RAINBOW ZINC	G002, G004, G234, G275, G437	
<b>DK223</b> 	SPCC	16 RAINBOW ZINC	G017	
<b>R014</b> 	PP	91 BLACK	G002, G004, G234, G275, G437	

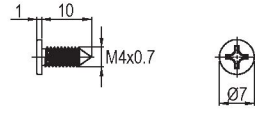

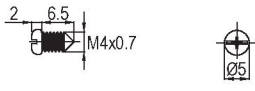
CODE รหัส	MATERIAL วัสดุ	FINISH สี	FOR USE WITH ใช้งานร่วมกับ	DIMENSION (mm) ขนาด (มม.)	
<b>DA015</b> 	ZDA 3	16 RAINBOW ZINC	A-602, A-702 A-603, A-703		
<b>DA016</b> 	ZDA 3	16 RAINBOW ZINC	A-602, A-702 A-603, A-703		
<b>DA017</b> 	ZDA 3	16 RAINBOW ZINC	A-602, A-702 A-603, A-703		
<b>DA047</b> 	ZDA 3	16 RAINBOW ZINC	A-602, A-702 A-603, A-703		
<b>DA158</b> 	ZDA 3	16 RAINBOW ZINC	A-653, A-753		
<b>DA160</b> 	ZDA 3	16 RAINBOW ZINC	A-653, A-753		
<b>DA161</b> 	ZDA 3	16 RAINBOW ZINC	A-653, A-753		
<b>DA162</b> 	ZDA 3	16 RAINBOW ZINC	A-653, A-753		
<b>DA163</b> 	ZDA 3	16 RAINBOW ZINC	A-653, A-753		

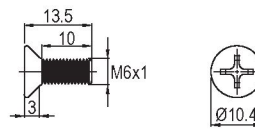

CODE รหัส	MATERIAL วัสดุ	FINISH สี	FOR USE WITH ใช้งานร่วมกับ	DIMENSION (mm) ขนาด (มม.)
DU033 	STEEL	16 RAINBOW ZINC	A-602, A-702 A-603, A-703	
DU036 	STEEL	16 RAINBOW ZINC	A-604	
DU048 	BRASS	00 RAW MATERIAL	DA017 SET (PAGE 157) DA161 SET (PAGE 158)	
DU083 	STEEL	16 RAINBOW ZINC	DA017 SET (PAGE 157) DA161 SET (PAGE 158)	
DU103 	STEEL	16 RAINBOW ZINC	A-602, A-702 A-603, A-703	
I006 	STEEL	16 RAINBOW ZINC	A-602, A-702, A-603, A-703 DA016 SET (PAGE 157) DA017 SET (PAGE 157) DA047 SET (PAGE 157)	
I028 	STEEL	16 RAINBOW ZINC	A-602, A-702, A-603, A-703 DA015 SET (PAGE 157)	
I064 	STEEL	01 NICKEL	D-622, D-655	
I065 	STEEL	01 NICKEL	D-622, D-655	







CODE รหัส	MATERIAL วัสดุ	FINISH สี	FOR USE WITH ใช้งานร่วมกับ	DIMENSION (mm) ขนาด (มม.)
<b>DA015 SET</b>				
<b>DA015</b>	ZDA 3	16 RAINBOW ZINC	A-602, A-702, A-603, A-703	
<b>I028</b>	STEEL	16 RAINBOW ZINC	A-602, A-702, A-603, A-703	
<b>DU103</b>	STEEL	16 RAINBOW ZINC	A-602, A-702, A-603, A-703	
<b>DA016 SET</b>				
<b>DA016</b>	ZDA 3	16 RAINBOW ZINC	A-602, A-702, A-603, A-703	
<b>I006</b>	STEEL	16 RAINBOW ZINC	A-602, A-702, A-603, A-703	
<b>DA017 SET</b>				
<b>DA017</b>	ZDA 3	16 RAINBOW ZINC	A-602, A-702, A-603, A-703	
<b>I006</b>	STEEL	16 RAINBOW ZINC	A-602, A-702, A-603, A-703	
			A-602, A-702, A-603, A-703 DA017 SET (PAGE 157) DA161 SET (PAGE 158)	
<b>DU048</b>	BRASS	00 RAW MATERIAL		
			A-602, A-702, A-603, A-703 DA017 SET (PAGE 157) DA161 SET (PAGE 158)	
<b>DU083</b>	STEEL	16 RAINBOW ZINC		
<b>DA047 SET</b>				
<b>DA047</b>	ZDA 3	16 RAINBOW ZINC	A-602, A-702, A-603, A-703	
<b>I006</b>	STEEL	16 RAINBOW ZINC	A-602, A-702, A-603, A-703	



CODE รหัส	MATERIAL วัสดุ	FINISH สี	FOR USE WITH ใช้งานร่วมกับ	DIMENSION (mm) ขนาด (มม.)
<b>DA158 SET</b>				
	ZDA 3	16 RAINBOW ZINC	A-637, A-737	
<b>DA158</b>				
	STEEL	16 RAINBOW ZINC	A-653, A-753	
<b>I028</b>				
	STEEL	16 RAINBOW ZINC	A-602, A-702, A-603, A-703	
<b>DU103</b>				
<b>DA160 SET</b>				
	ZDA 3	16 RAINBOW ZINC	A-653, A-753	
<b>DA160</b>				
	STEEL	16 RAINBOW ZINC	A-602, A-702, A-603, A-703 DA016 SET (PAGE 157) DA017 SET (PAGE 157) DA047 SET (PAGE 157)	
<b>I006</b>				
<b>DA161 SET</b>				
	ZDA 3	16 RAINBOW ZINC	A-653, A-753	
<b>DA161</b>				
	BRASS	00 RAW MATERIAL	DA016 SET (PAGE 157) DA161 SET (PAGE 158)	
<b>DU048</b>				
	STEEL	16 RAINBOW ZINC	DA016 SET (PAGE 157) DA161 SET (PAGE 158)	
<b>DU083</b>				
<b>DA162 SET</b>				
	ZDA 3	16 RAINBOW ZINC	A-653, A-753	
<b>DA162</b>				
	STEEL	16 RAINBOW ZINC	A-602, A-702, A-603, A-703	
<b>I006</b>				



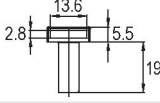

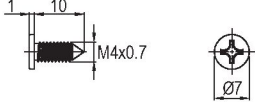
CODE	MATERIAL	FINISH	FOR USE WITH	DIMENSION (mm)
รหัส	วัสดุ	สี	ใช้งานร่วมกับ	ขนาด(มม.)
<b>DA163 SET</b>				
				
<b>DA163</b>	ZDA 3	16 RAINBOW ZINC	A-653, A-753	
				
<b>I006</b>	STEEL	16 RAINBOW ZINC	A-602, A-702, A-603, A-703	



CODE รหัส	MATERIAL วัสดุ	FINISH สี	FOR USE WITH ใช้งานร่วมกับ			DIMENSION (mm) ขนาด(มม.)
R133	PP	91 BLACK	A-601, A-605, A-614, A-616, A-628, A-629			
R134	PP	91 BLACK	A-602, A-608			
R135	PP	91 BLACK	A-606			
R136	PP	91 BLACK	A-703A, A-703C, A-711B, A-711C			
R137	PP	91 BLACK	A-711, A-717, A-703H, A-703V, A-715			
R138	PP	91 BLACK	A-603A			
R139	PP	91 BLACK	A-603H, A-603V, A-611, A-615, A-617, A-619 A-620			
R140	PP	91 BLACK	A-734, A-735			



CODE รหัส	MATERIAL วัสดุ	FINISH สี	FOR USE WITH ใช้งานร่วมกับ			DIMENSION (mm) ขนาด(มม.)		
<b>R254</b>	PP	91 BLACK	A-636H, A-736H A-636V, A-736V					
<b>R255</b>	PP	91 BLACK	A-636H, A-736H A-636V, A-736V					
<b>R282</b>	PP	91 BLACK	D-107, D-108					
<b>R283</b>	PP	91 BLACK	D-107, D-108					
<b>R243</b>	PP	91 BLACK	A-601, A-701, A-616, A-716					





CODE	MATERIAL	FINISH	FOR USE WITH	DIMENSION (mm)
รหัส	วัสดุ	สี	ใช้งานร่วมกับ	ขนาด(มม.)

AS002

-

94 GRAY

A-664

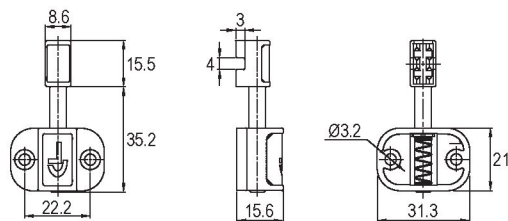
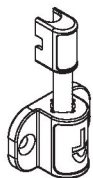

ROLLER SET

-

15 WHITE ZINC

A-642

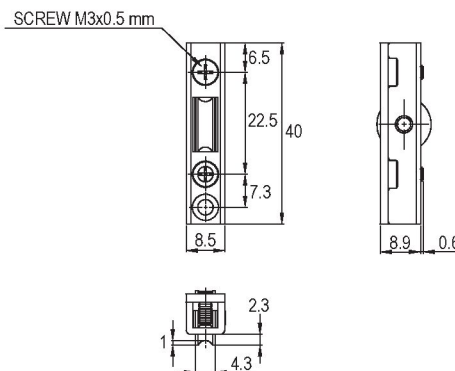
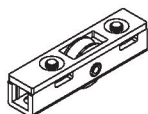

4-05-03-I023-L

01 NICKEL  
03 CHROME  
04 BLACK E.D.P.  
27 SATIN-NICKEL  
28 SATIN-CHROME  
51 SILVER

SWING GLASS DOOR CABINET

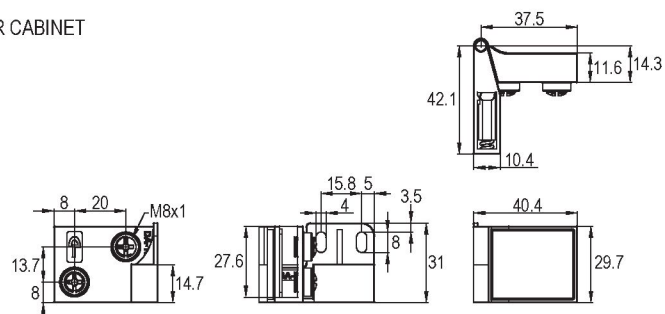

4-05-03-I023-R

01 NICKEL  
03 CHROME  
04 BLACK E.D.P.  
27 SATIN-NICKEL  
28 SATIN-CHROME  
51 SILVER



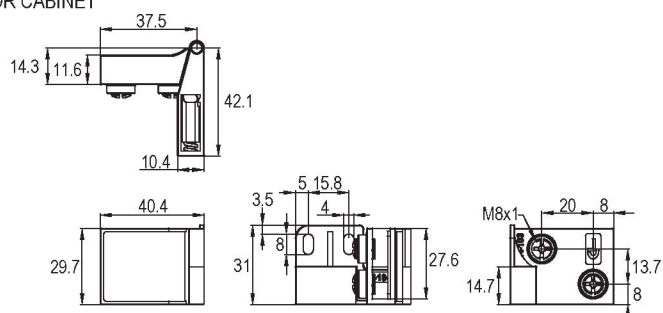
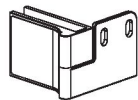





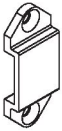
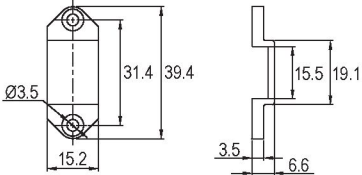
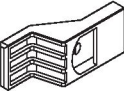
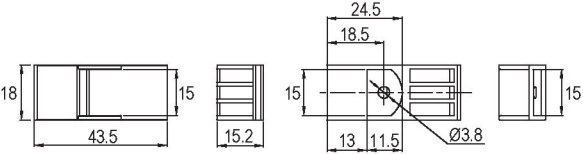

SWING GLASS DOOR CABINET

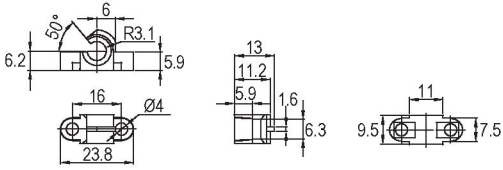

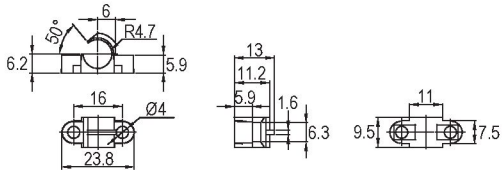

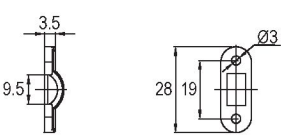
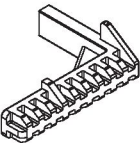
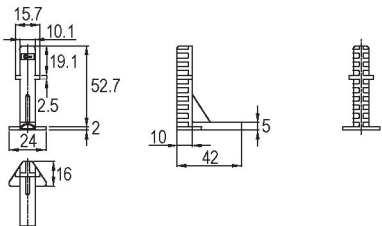
CODE รหัส	MATERIAL วัสดุ	FINISH สี	FOR USE WITH ใช้งานร่วมกับ	DIMENSION (mm) ขนาด(มม.)		
DA005	ZDA 3	01 NICKEL	A-612, A-712, A-759, A-760, A-761			
DA006	ZDA 3	01 NICKEL	A-612, A-712, A-759, A-760, A-761			
DA014	ZDA 3	01 NICKEL	A-612, A-712 A-759, A-760, A-761			
DA145	ZDA 3	01 NICKEL	A-758V			
DA211	ZDA 3	01 NICKEL	A-758V			
DA212	ZDA 3	01 NICKEL	A-758V			
DA251/L	ZDA 3	01 NICKEL	A-758H			
DA252/R	ZDA 3	01 NICKEL	A-758H			

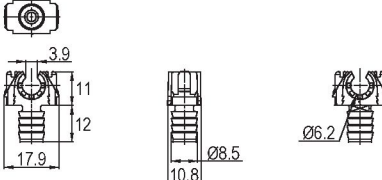

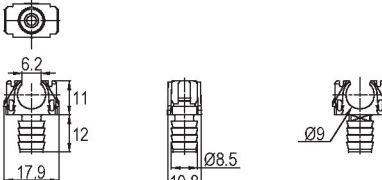
CODE รหัส	MATERIAL วัสดุ	FINISH สี	FOR USE WITH ใช้งานร่วมกับ	DIMENSION (mm) ขนาด(มม.)
<b>R036</b> 	POM	91 BLACK	A-618+(ANTI-TILT), A-718+(ANTI-TILT), A-662-TYPE A+(ANTI-TILT), A-762-TYPE A+(ANTI-TILT)	
<b>R037</b> 	POM	91 BLACK	A-618+(ANTI-TILT), A-718+(ANTI-TILT), A-662-TYPE A+(ANTI-TILT), A-762-TYPE A+(ANTI-TILT)	
<b>R039</b> 	PA66	91 BLACK	A-612, A-712, A-759, A-760, A-761	
<b>R040</b> 	PA66	91 BLACK	A-612, A-712, A-759, A-760, A-761	
<b>R148</b> 	PP	91 BLACK	A-643+(ANTI-TILT), A-743+(ANTI-TILT), A-662-TYPE B+(ANTI-TILT), A-762-TYPE B+(ANTI-TILT)	
<b>R175</b> 	PA66+GF25%	91 BLACK	A-643+(ANTI-TILT), A-743+(ANTI-TILT), A-662-TYPE B+(ANTI-TILT), A-762-TYPE B+(ANTI-TILT)	
<b>R196</b> 	PA66	94 GRAY	A-758V-TYPE A, A-758H-TYPE C	
<b>R197</b> 	PA66	94 GRAY	A-758V-TYPE A, A-758H-TYPE C	



CODE รหัส	MATERIAL วัสดุ	FINISH สี	FOR USE WITH ใช้งานร่วมกับ	DIMENSION (mm) ขนาด(มม.)
R235	PA66	94 GRAY	A-758V-TYPE B, A-758H-TYPE D	
R236	PA66	94 GRAY	A-758V-TYPE B, A-758H-TYPE D	
R258	PP	71 WHITE	A-765	
DA011	ZDA 3	01 NICKEL	A-612, A-712, A-759, A-760, A-761	
DA215	ZDA 3	01 NICKEL	A-758	
DK210	SPCC	01 NICKEL	A-644	
DK457	SPCC	16 RAINBOW ZINC	VT001	





CODE รหัส	MATERIAL วัสดุ	FINISH สี	FOR USE WITH ใช้งานร่วมกับ	DIMENSION (mm) ขนาด(มม.)
<b>G088</b>	SPCC	01 NICKEL	A-618+(ANTI-TILT), A-718+(ANTI-TILT), A-662+(ANTI-TILT), A-762+(ANTI-TILT)	
<b>DA028</b>	SWR-M12	01 NICKEL	A-612, A-712, A-759, A-760, A-761	
<b>DA128</b>	SWR-M6	05 BLACK	A-643+(ANTI-TILT) A-743+(ANTI-TILT) A-662-TYPE B+(ANTI-TILT), A-762-TYPE B+(ANTI-TILT)	
<b>DA217</b>	SWR-M12	01 NICKEL	A-664	



TYPES OF CAMS ประเภทของ錠	LENGTH (mm) ความยาว	CODE (C) รหัส	ALTERNATE CODE (G) รหัสที่ใช้แทนกันได้	PAGE หน้า
	20	C27	: G029	172
	22.5	C99	: G230	172
	25	C49	: G115	172
	25	C130	: G303	172
	26.5	C97	: G227	172
	28.5	C76	: G152	172
	28.7	C121	: G290	172
	28.7	CT70	: G141	172
	30	C91	: G203	172
	32	C175	: G374	173
	34	C37	: G053	173
	35.5	C194	: G397	173
	37	C50	: G116	173
	37.5	C171	: G370	173
	39.2	C75	: G148	173
	40	CT89	: G201	173
	42.5	C01	: G061	173
	42.5	CX80	: G159	174
	45	C36	: G052	174
	45.5	C182	: G382	174
	49	C02	: G062	174
	50	C34	: G050	174
	50	CT90	: G202	174
	52	C31	: G095	175
	55.5	C187	: G388	175
	55.5	CT243	: G548	175
	60	C48	: G114	175
	63.5	CT101	: G238	175
	64.5	-	: G019	175
	70	C39	: G055	176
	77.5	C225	: G480	176
	110	C151	: G340	176
	20	C181	: G381	177
	25.5	C69	: G140	177
	26	C166	: G364	177
	26	C193	: G396	177
	26.8	C11	: G071	177
	26.8	C65	: G131	177
	27	C10	: G070	177
	27	C95	: G215	177
	27.7	C15	: G077	178
	27.7	C198	: G405	178
	29	C219	: G451	178
	30	C112	: G277	178
	31.5	CT223	: G468	178
	32.5	C110	: G256	178
	32.5	CT110	: G256	178
	33	C203	: G414	178
	33.8	CT63	: G091	179
	34	C188	: G389	179
	34	C201	: G408	179
	34.2	CT123	: G295	179



TYPES OF CAMS ประเภทของลิ้น	LENGTH (mm) ความยาว	CODE (C) รหัส	ALTERNATE CODE (G) รหัสที่ใช้แทนกันได้	PAGE หน้า
	34.5	C113	: G278	179
	34.5	C157	: G349	179
	35	CT83	: G180	179
	35.5	C106	: G245	<b>180</b>
	36	C147	: G332	180
	36	C227	: G497	180
	36.3	C155	: G346	180
	37	C59	: G126	180
	37.5	C84	: G186	180
	37.5	C144	: G329	180
	37.5	C164	: G360	<b>181</b>
	37.5	C170	: G369	181
	38.2	C154	: G345	181
	39	C93	: G205	181
	39	C98	: G228	181
	39	C120	: G287	181
	39	C133	: G306	181
	39.2	C82	: G177	<b>182</b>
	39.2	C217	: G446	182
	39.5	C45	: G107	182
	40.5	C192	: G395	182
	40.6	C07	: G067	182
	40.6	C78	: G157	182
	41	C12	: G072	182
	41	C14	: G076	<b>183</b>
	41	C150	: G339	183
	41	C206	: G417	183
	41	C257	: G590	183
	41.2	C06	: G066	183
	41.6	C03	: G063	183
	42	C08	: G068	183
	42	C16	: G078	<b>184</b>
	42	CX81	: G163	184
	42	CT129	: G302	184
	42.3	C09	: G069	184
	42.5	C174	: G373	184
	43	C21	: G083	184
	43.5	C195	: G398	184
	44.5	CT199	: G406	<b>185</b>
	45	C42	: G102	185
	45	CT118	: G284	185
	45	C131	: G304	185
	45	C204	: G415	185
	45	C207	: G418	185
	45	CT228	: G503	185
	45	CT239	: G543	<b>186</b>
	45	C240	: G536	186
	45	C241	: G544	186
	45.5	C96	: G222	186
	45.5	C145	: G330	186
	45.5	C149	: G338	186
	45.8	C247	: G560	<b>187</b>
	46	CT213	: G441	187



TYPES OF CAMS ประเภทของคั่น	LENGTH (mm) ความยาว	CODE (C) รหัส	ALTERNATE CODE (G) รหัสที่ใช้แทนกันได้	PAGE หน้า	
	46.5	C 168	: G367	187	
	46.5	CT244	: G550	187	
	47.5	C 251	: G566	187	
	47.6	CT220	: G435	187	
	47.8	C 153	: G344	<b>188</b>	
	48	C 23	: G085	188	
	48.7	C 04	: G064	188	
	48.8	C 66	: G133	188	
	49	-	: G020	188	
	49	CT237	: G518	188	
	50	C 85	: G187	<b>189</b>	
	50.5	C 140	: G317	189	
	51	C 208	: G419	189	
	51	C 214	: G443	189	
	51.5	C 230	: G507	189	
	52	C 100	: G237	189	
	52.7	C 158	: G350	<b>190</b>	
	53.5	C 22	: G084	190	
	53.5	C 139	: G316	190	
	55.2	CT224	: G469	190	
	57.5	C 87	: G193	190	
	57.5	C 148	: G337	190	
	58.3	C 156	: G347	<b>191</b>	
	58.5	C 134	: G307	191	
	59.5	C 92	: G204	191	
	59.5	C 125	: G297	191	
	59.5	C 169	: G368	191	
	59.5	C 200	: G407	191	
	60.5	C 152	: G342	<b>192</b>	
	62.5	CT218	: G447	192	
	64.5	C 167	: G366	192	
	68.5	CT176	: G375	192	
	68.5	CT179	: G379	192	
	70.5	CT159	: G351	192	
		34.5	C 103	: G240	<b>193</b>
		35.6	C 05	: G065	193
		37	C 33	: G097	193
		40	CT64	: G130	193
		41.2	C 46	: G108	193
		42.5	C 17	: G079	193
45		C 35	: G051	<b>194</b>	
46.9		C 226	: G493	194	
49		C 18	: G080	194	
49		CT177	: G377	194	
	52.5	CX246	: G555	194	
	55	CT94	: G214	194	
	58	C 197	: G404	<b>195</b>	
	60.5	C 212	: G439	195	



TYPES OF CAMS ประเภทของลิ้น	LENGTH (mm) ความยาว	CODE (C) รหัส	ALTERNATE CODE (G) รหัสที่ใช้แทนกันได้	PAGE หน้า
	23.4	C 161	: G355	<b>196</b>
	25.8	C 137	: G313	196
	32	C 173	: G372	196
	33	C 205	: G416	196
	33	C 210	: G424	196
	37	C 216	: G445	196
	38	C 186	: G387	196
	39	C 29	: G041	<b>197</b>
	39	C 242	: G545	197
	39	C 245	: G551	197
	39.2	C 74	: G147	197
	41	C 124	: G296	197
	41	C 236	: G513	197
	41.5	C 235	: G512	197
	42.2	C 25	: G028	<b>198</b>
	46	C 189	: G390	198
	46	C 215	: G444	198
	46.5	C 209	: G420	198
	47.0	C 255	: G588	198
	47.5	C 256	: G589	198
	48.2	C 196	: G399	<b>199</b>
	48.5	C 40	: G060	199
	48.5	C 41	: G101	199
	48.5	C 47	: G111	199
	52.5	C 56	: G123	199



LENGTH ความยาว	CODE รหัส	ALTERNATE CODE (G) รหัสที่ใช้แทนกันได้	MATERIAL วัสดุ	FINISH สี	DIMENSION (mm) ขนาด (มม.)
20.0mm	C27	G029	SPCC	16 RAINBOW ZINC	
22.5mm	C99	G230	SPCC	16 RAINBOW ZINC	
25.0mm	C49	G115	SPCC	16 RAINBOW ZINC	
25.0mm	C130	G303	SPCC	16 RAINBOW ZINC	
26.5mm	C97	G227	SPCC	16 RAINBOW ZINC	
28.5mm	C76	G152	SPCC	16 RAINBOW ZINC	
28.7mm	C121	G290	SPCC	16 RAINBOW ZINC	
28.7mm	CT70	G141	SPCC	16 RAINBOW ZINC	
30.0mm	C91	G203	SPCC	16 RAINBOW ZINC	



LENGTH ความยาว	CODE รหัส	ALTERNATE CODE (G) รหัสที่ใช้แทนกันได้	MATERIAL วัสดุ	FINISH สี	DIMENSION (mm) ขนาด (มม.)	
32.0mm	C175	G374	SPCC	16 RAINBOW ZINC		
34.0mm	C37	G053	SPCC	16 RAINBOW ZINC		
35.5mm	C194	G397	SPCC	16 RAINBOW ZINC		
37.0mm	C50	G116	SPCC	16 RAINBOW ZINC		
37.5mm	C171	G370	SPCC	16 RAINBOW ZINC		
39.2mm	C75	G148	SPCC	16 RAINBOW ZINC		
40.0mm	CT89	G201	SPCC	16 RAINBOW ZINC		
42.5mm	C01	G061	SPCC	16 RAINBOW ZINC		



LENGTH ความยาว	CODE รหัส	ALTERNATE CODE (G) รหัสที่ใช้แทนกันได้	MATERIAL วัสดุ	FINISH สี	DIMENSION (mm) ขนาด (มม.)	
42.5mm	CX80	G159	SPCC	16 RAINBOW ZINC		
45.0mm	C36	G052	SPCC	16 RAINBOW ZINC		
45.5mm	C182	G382	SPCC	16 RAINBOW ZINC		
49.0mm	C02	G062	SPCC	16 RAINBOW ZINC		
50.0mm	C34	G050	SPCC	16 RAINBOW ZINC		
50.0mm	CT90	G202	SPCC	16 RAINBOW ZINC		





LENGTH ความยาว	CODE รหัส	ALTERNATE CODE (G) รหัสที่ใช้แทนกันได้	MATERIAL วัสดุ	FINISH สี	DIMENSION (mm) ขนาด (มม.)	
52.0mm	C31	G095	SPCC	16 RAINBOW ZINC		
55.5mm	C187	G388	SPCC	16 RAINBOW ZINC		
55.5mm	CT243	G548	SPCC	16 RAINBOW ZINC		
60.0mm	C48	G114	SPCC	16 RAINBOW ZINC		
63.5mm	CT101	G238	SPCC	16 RAINBOW ZINC		
64.5mm	-	G019	SPCC	16 RAINBOW ZINC		



LENGTH ความยาว	CODE รหัส	ALTERNATE CODE (G) รหัสที่ใช้แทนกันได้	MATERIAL วัสดุ	FINISH สี	DIMENSION (mm) ขนาด (มม.)
70.0mm	C39	G055	SPCC	16 RAINBOW ZINC	
77.5mm	C225	G480	SPCC	16 RAINBOW ZINC	
110.0mm	C151	G340	SPCC	16 RAINBOW ZINC	



LENGTH	CODE	ALTERNATE CODE (G)	MATERIAL	FINISH	DIMENSION (mm)	
ความยาว	รหัส	รหัสที่ใช้แทนกันได้	วัสดุ	สี	ขนาด (มม.)	
20.0mm	C181	G381	SPCC	16 RAINBOW ZINC		
25.5mm	C69	G140	SPCC	16 RAINBOW ZINC		
26.0mm	C166	G364	SPCC	16 RAINBOW ZINC		
26.0mm	C193	G396	SPCC	16 RAINBOW ZINC		
26.8mm	C11	G071	SPCC	16 RAINBOW ZINC		
26.8mm	C65	G131	SPCC	16 RAINBOW ZINC		
27.0mm	C10	G070	SPCC	16 RAINBOW ZINC		
27.0mm	C95	G215	SPCC	16 RAINBOW ZINC		



LENGTH ความยาว	CODE รหัส	ALTERNATE CODE (G) รหัสที่ใช้แทนกันได้	MATERIAL วัสดุ	FINISH สี	DIMENSION (mm) ขนาด (มม.)	
27.7mm	C15	G077	SPCC	16 RAINBOW ZINC		
27.7mm	C198	G405	SPCC	16 RAINBOW ZINC		
29.0mm	C219	G451	SPCC	16 RAINBOW ZINC		
30.0mm	C112	G277	SPCC	16 RAINBOW ZINC		
31.5mm	CT223	G468	SPCC	16 RAINBOW ZINC		
32.5mm	C110	G256	SPCC	16 RAINBOW ZINC		
32.5mm	CT110	G256	SPCC	16 RAINBOW ZINC		
33.0mm	C203	G414	SPCC	16 RAINBOW ZINC		



LENGTH ความยาว	CODE รหัส	ALTERNATE CODE (G) รหัสที่ใช้แทนกันได้	MATERIAL วัสดุ	FINISH สี	DIMENSION (mm) ขนาด (มม.)	
33.8mm	CT63	G091	SPCC	16 RAINBOW ZINC		
34.0mm	C188	G389	SPCC	16 RAINBOW ZINC		
34.0mm	C201	G408	SPCC	16 RAINBOW ZINC		
34.2mm	CT123	G295	SPCC	16 RAINBOW ZINC		
34.5mm	C113	G278	SPCC	16 RAINBOW ZINC		
34.5mm	C157	G349	SPCC	16 RAINBOW ZINC		
35.0mm	CT83	G180	SPCC	16 RAINBOW ZINC		



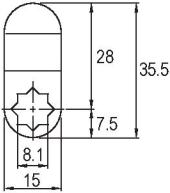
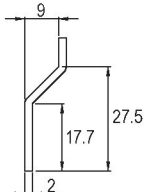
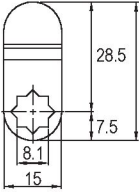
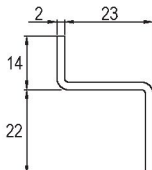
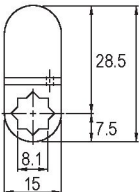
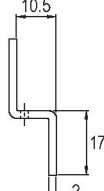
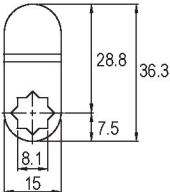
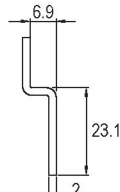
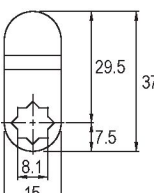
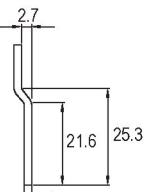
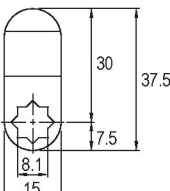
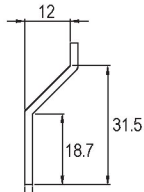
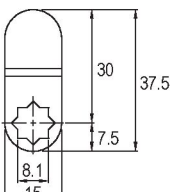
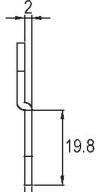

LENGTH ความยาว	CODE รหัส	ALTERNATE CODE (G) รหัสที่ใช้แทนกันได้	MATERIAL วัสดุ	FINISH สี	DIMENSION (mm) ขนาด (มม.)	
35.5mm	C106	G245	SPCC	16 RAINBOW ZINC		
36.0mm	C147	G332	SPCC	16 RAINBOW ZINC		
36.0mm	C227	G497	SPCC	16 RAINBOW ZINC		
36.3mm	C155	G346	SPCC	16 RAINBOW ZINC		
37.0mm	C59	G126	SPCC	16 RAINBOW ZINC		
37.5mm	C84	G186	SPCC	16 RAINBOW ZINC		
37.5mm	C144	G329	SPCC	16 RAINBOW ZINC		

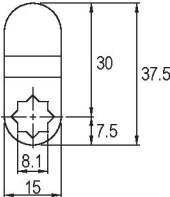
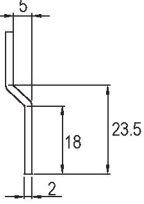
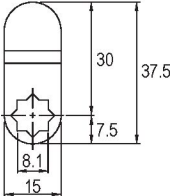
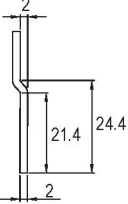
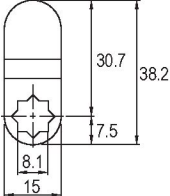
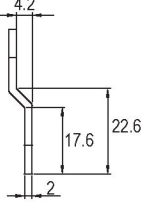
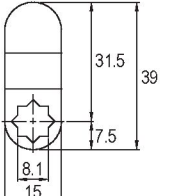
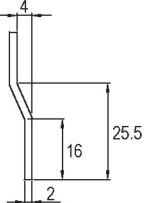
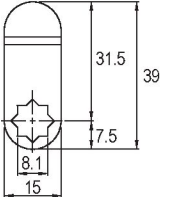
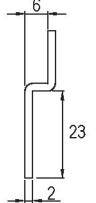
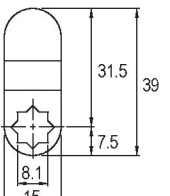
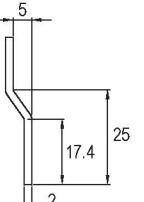
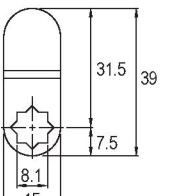
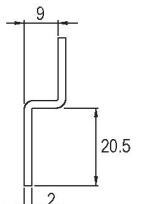

LENGTH ความยาว	CODE รหัส	ALTERNATE CODE (G) รหัสที่ใช้แทนกันได้	MATERIAL วัสดุ	FINISH สี	DIMENSION (mm) ขนาด (มม.)	
37.5mm	C164	G360	SPCC	16 RAINBOW ZINC		
37.5mm	C170	G369	SPCC	16 RAINBOW ZINC		
38.2mm	C154	G345	SPCC	16 RAINBOW ZINC		
39.0mm	C93	G205	SPCC	16 RAINBOW ZINC		
39.0mm	C98	G228	SPCC	16 RAINBOW ZINC		
39.0mm	C120	G287	SPCC	16 RAINBOW ZINC		
39.0mm	C133	G306	SPCC	16 RAINBOW ZINC		

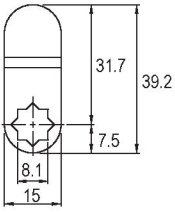
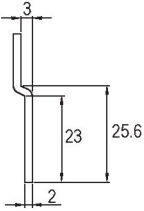
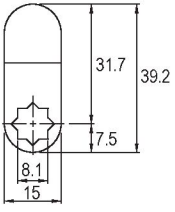
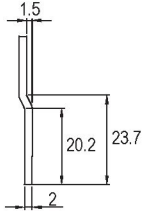
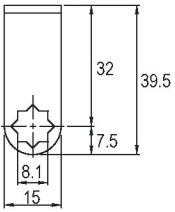

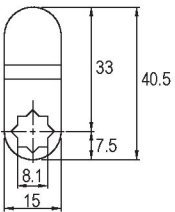
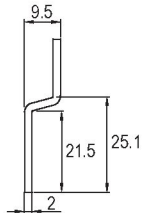
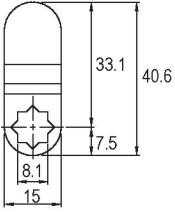
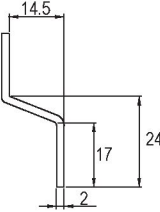
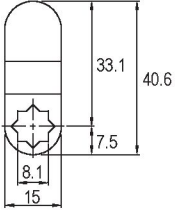
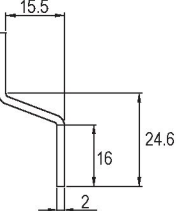
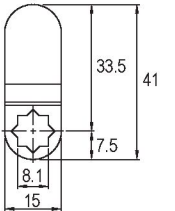
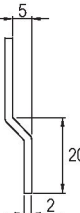
LENGTH ความยาว	CODE รหัส	ALTERNATE CODE (G) รหัสที่ใช้แทนกันได้	MATERIAL วัสดุ	FINISH สี	DIMENSION (mm) ขนาด (มม.)	
39.2mm	C82	G177	SPCC	16 RAINBOW ZINC		
39.2mm	C217	G446	SPCC	16 RAINBOW ZINC		
39.5mm	C45	G107	SPCC	16 RAINBOW ZINC		
40.5mm	C192	G395	SPCC	16 RAINBOW ZINC		
40.6mm	C07	G067	SPCC	16 RAINBOW ZINC		
40.6mm	C78	G157	SPCC	16 RAINBOW ZINC		
41.0mm	C12	G072	SPCC	16 RAINBOW ZINC		





LENGTH ความยาว	CODE รหัส	ALTERNATE CODE (G) รหัสที่ใช้แทนกันได้	MATERIAL วัสดุ	FINISH สี	DIMENSION (mm) ขนาด (มม.)	
41.0mm	C14	G076	SPCC	16 RAINBOW ZINC		
41.0mm	C150	G339	SPCC	16 RAINBOW ZINC		
41.0mm	C206	G417	SPCC	16 RAINBOW ZINC		
41.0mm	C257	G590	SPCC	16 RAINBOW ZINC		
41.2mm	C06	G066	SPCC	16 RAINBOW ZINC		
41.6mm	C03	G063	SPCC	16 RAINBOW ZINC		
42.0mm	C08	G068	SPCC	16 RAINBOW ZINC		



LENGTH ความยาว	CODE รหัส	ALTERNATE CODE (G) รหัสที่ใช้แทนกันได้	MATERIAL วัสดุ	FINISH สี	DIMENSION (mm) ขนาด (มม.)	
42.0mm	C16	G078	SPCC	16 RAINBOW ZINC		
42.0mm	CX81	G163	SPCC	16 RAINBOW ZINC		
42.0mm	CT129	G302	SPCC	16 RAINBOW ZINC		
42.3mm	C09	G069	SPCC	16 RAINBOW ZINC		
42.5mm	C174	G373	SPCC	16 RAINBOW ZINC		
43.0mm	C21	G083	SPCC	16 RAINBOW ZINC		
43.5mm	C195	G398	SPCC	16 RAINBOW ZINC		

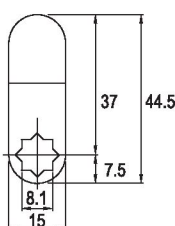
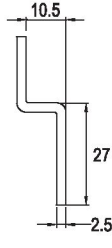
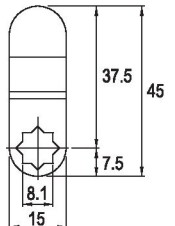
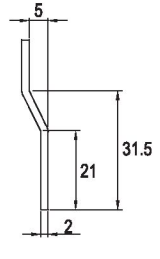
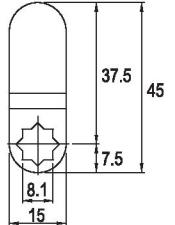
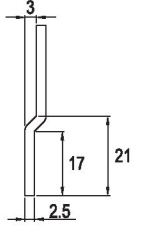
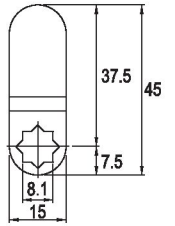
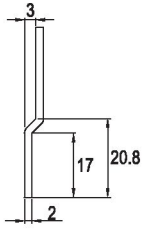
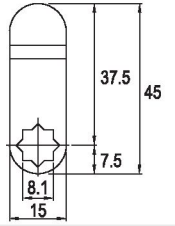
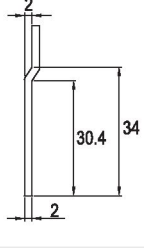
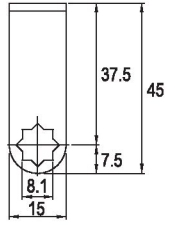
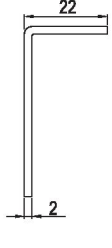
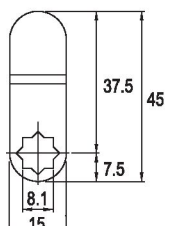
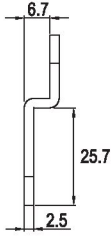

LENGTH ความยาว	CODE รหัส	ALTERNATE CODE (G) รหัสที่ใช้แทนกันได้	MATERIAL วัสดุ	FINISH สี	DIMENSION (mm) ขนาด (มม.)	
44.5mm	CT199	G406	SPCC	16 RAINBOW ZINC		
45.0mm	C42	G102	SPCC	16 RAINBOW ZINC		
45.0mm	CT118	G284	SPCC	16 RAINBOW ZINC		
45.0mm	C131	G304	SPCC	16 RAINBOW ZINC		
45.0mm	C204	G415	SPCC	16 RAINBOW ZINC		
45.0mm	C207	G418	SPCC	16 RAINBOW ZINC		
45.0mm	CT228	G503	SPCC	16 RAINBOW ZINC		



LENGTH ความยาว	CODE รหัส	ALTERNATE CODE (G) รหัสที่ใช้แทนกันได้	MATERIAL วัสดุ	FINISH สี	DIMENSION (mm) ขนาด (มม.)	
45.0mm	CT239	G543	SPCC	16 RAINBOW ZINC		
45.0mm	C240	G536	SPCC	16 RAINBOW ZINC		
45.0mm	C241	G544	SPCC	16 RAINBOW ZINC		
45.5mm	C96	G222	SPCC	16 RAINBOW ZINC		
45.5mm	C145	G330	SPCC	16 RAINBOW ZINC		
45.5mm	C149	G338	SPCC	16 RAINBOW ZINC		



LENGTH ความยาว	CODE รหัส	ALTERNATE CODE (G) รหัสที่ใช้แทนกันได้	MATERIAL วัสดุ	FINISH สี	DIMENSION (mm) ขนาด (มม.)	
45.8mm	C247	G560	SPCC	16 RAINBOW ZINC		
46.0mm	CT213	G441	SPCC	16 RAINBOW ZINC		
46.5mm	C168	G367	SPCC	16 RAINBOW ZINC		
46.5mm	CT244	G550	SPCC	16 RAINBOW ZINC		
47.5mm	C251	G566	SPCC	01 NICKEL		
47.6mm	CT220	G435	SPCC	16 RAINBOW ZINC		



LENGTH ความยาว	CODE รหัส	ALTERNATE CODE (G) รหัสที่ใช้แทนกันได้	MATERIAL วัสดุ	FINISH สี	DIMENSION (mm) ขนาด (มม.)	
47.8mm	C153	G344	SPCC	16 RAINBOW ZINC		
48.0mm	C23	G085	SPCC	16 RAINBOW ZINC		
48.7mm	C04	G064	SPCC	16 RAINBOW ZINC		
48.8mm	C66	G133	SPCC	16 RAINBOW ZINC		
49.0mm	-	G020	SPCC	16 RAINBOW ZINC		
49.0mm	CT237	G518	SPCC	16 RAINBOW ZINC		



LENGTH ความยาว	CODE รหัส	ALTERNATE CODE (G) รหัสที่ใช้แทนกันได้	MATERIAL วัสดุ	FINISH สี	DIMENSION (mm) ขนาด (มม.)	
50.0mm	C85	G187	SPCC	16 RAINBOW ZINC		
50.5mm	C140	G317	SPCC	16 RAINBOW ZINC		
51.0mm	C208	G419	SPCC	16 RAINBOW ZINC		
51.0mm	C214	G443	SPCC	16 RAINBOW ZINC		
51.5mm	C230	G507	SPCC	16 RAINBOW ZINC		
52.0mm	C100	G237	SPCC	16 RAINBOW ZINC		



LENGTH ความยาว	CODE รหัส	ALTERNATE CODE (G) รหัสที่ใช้แทนกันได้	MATERIAL วัสดุ	FINISH สี	DIMENSION (mm) ขนาด (มม.)	
52.7mm	C158	G350	SPCC	16 RAINBOW ZINC		
53.5mm	C22	G084	SPCC	16 RAINBOW ZINC		
53.5mm	C139	G316	SPCC	16 RAINBOW ZINC		
55.2mm	CT224	G469	SPCC	16 RAINBOW ZINC		
57.5mm	C87	G193	SPCC	16 RAINBOW ZINC		
57.5mm	C148	G337	SPCC	16 RAINBOW ZINC		





LENGTH ความยาว	CODE รหัส	ALTERNATE CODE (G) รหัสที่ใช้แทนกันได้	MATERIAL วัสดุ	FINISH สี	DIMENSION (mm) ขนาด (มม.)	
58.3mm	C156	G347	SPCC	16 RAINBOW ZINC		
58.5mm	C134	G307	SPCC	16 RAINBOW ZINC		
59.5mm	C92	G204	SPCC	16 RAINBOW ZINC		
59.5mm	C125	G297	SPCC	16 RAINBOW ZINC		
59.5mm	C169	G368	SPCC	16 RAINBOW ZINC		
59.5mm	C200	G407	SPCC	16 RAINBOW ZINC		









LENGTH ความยาว	CODE รหัส	ALTERNATE CODE (G) รหัสที่ใช้แทนกันได้	MATERIAL วัสดุ	FINISH สี	DIMENSION (mm) ขนาด (มม.)	
60.5mm	C152	G342	SPCC	16 RAINBOW ZINC		
62.5mm	CT218	G447	SPCC	16 RAINBOW ZINC		
64.5mm	C167	G366	SPCC	16 RAINBOW ZINC		
68.5mm	CT176	G375	SPCC	16 RAINBOW ZINC		
68.5mm	CT179	G379	SPCC	16 RAINBOW ZINC		
70.5mm	CT159	G351	SPCC	16 RAINBOW ZINC		

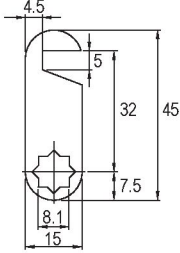
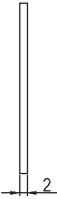

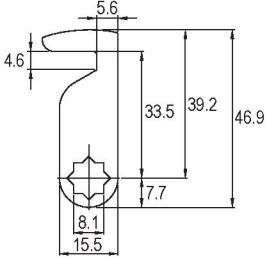
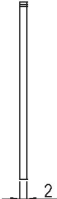
LENGTH ความยาว	CODE รหัส	ALTERNATE CODE (G) รหัสที่ใช้แทนกันได้	MATERIAL วัสดุ	FINISH สี	DIMENSION (mm) ขนาด (มม.)
34.5mm	C103	G240	SPCC	16 RAINBOW ZINC	
35.6mm	C05	G065	SPCC	16 RAINBOW ZINC	
37.0mm	C33	G097	SPCC	16 RAINBOW ZINC	
40.0mm	CT64	G130	SPCC	16 RAINBOW ZINC	
41.2mm	C46	G108	SPCC	16 RAINBOW ZINC	
42.5mm	C17	G079	SPCC	16 RAINBOW ZINC	

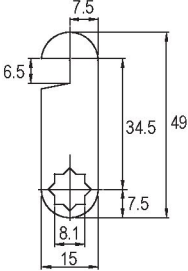
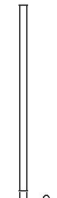
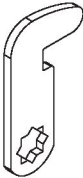
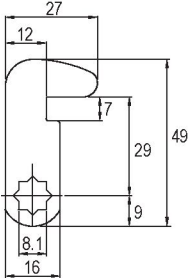
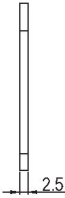
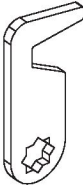
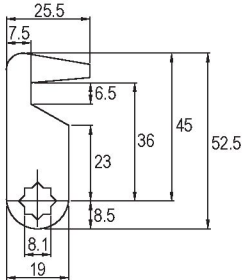
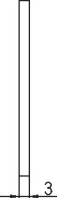

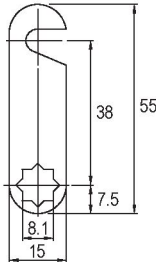
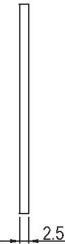
LENGTH ความยาว	CODE รหัส	ALTERNATE CODE (G) รหัสที่ใช้แทนกันได้	MATERIAL วัสดุ	FINISH สี	DIMENSION (mm) ขนาด (มม.)
45.0mm	C35	G051	SPCC	16 RAINBOW ZINC	  
46.9mm	C226	G493	SPCC	16 RAINBOW ZINC	  
49.0mm	C18	G080	SPCC	16 RAINBOW ZINC	  
49.0mm	CT177	G377	SPCC	16 RAINBOW ZINC	  
52.5mm	CX246	G555	SPCC	16 RAINBOW ZINC	  
55.0mm	CT94	G214	SPCC	16 RAINBOW ZINC	  

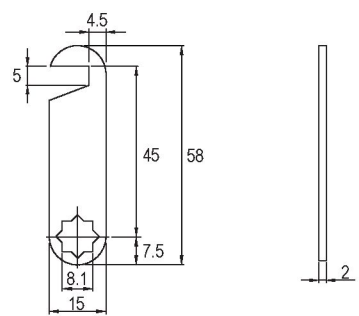
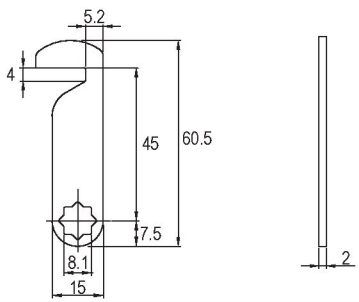
LENGTH	CODE	ALTERNATE CODE (G)	MATERIAL	FINISH	DIMENSION (mm)
ความยาว	รหัส	รหัสที่ใช้แทนกันได้	วัสดุ	สี	ขนาด (มม.)
58.0mm	C197	G404	SPCC	16 RAINBOW ZINC	
60.5mm	C212	G439	SPCC	16 RAINBOW ZINC	



LENGTH ความยาว	CODE รหัส	ALTERNATE CODE (G) รหัสที่ใช้แทนกันได้	MATERIAL วัสดุ	FINISH สี	DIMENSION (mm) ขนาด (มม.)	
23.4mm	C161	G355	SPCC	16 RAINBOW ZINC		
25.8mm	C137	G313	SPCC	16 RAINBOW ZINC		
32.0mm	C173	G372	SPCC	16 RAINBOW ZINC		
33.0mm	C205	G416	SPCC	16 RAINBOW ZINC		
33.0mm	C210	G424	SPCC	16 RAINBOW ZINC		
37.0mm	C216	G445	SPCC	16 RAINBOW ZINC		
38.0mm	C186	G387	SPCC	16 RAINBOW ZINC		



LENGTH ความยาว	CODE รหัส	ALTERNATE CODE (G) รหัสที่ใช้แทนกันได้	MATERIAL วัสดุ	FINISH สี	DIMENSION (mm) ขนาด (มม.)	
39.0mm	C29	G041	SPCC	16 RAINBOW ZINC		
39.0mm	C242	G545	SPCC	16 RAINBOW ZINC		
39.0mm	C245	G551	SPCC	16 RAINBOW ZINC		
39.2mm	C74	G147	SPCC	16 RAINBOW ZINC		
41.0mm	C124	G296	SPCC	16 RAINBOW ZINC		
41.0mm	C236	G513	SPCC	16 RAINBOW ZINC		
41.5mm	C235	G512	SPCC	16 RAINBOW ZINC		



LENGTH	CODE	ALTERNATE CODE (G)	MATERIAL	FINISH	DIMENSION (mm)	
ความยาว	รหัส	รหัสที่ใช้แทนกันได้	วัสดุ	สี	ขนาด (มม.)	
42.2mm	C25	G028	SPCC	16 RAINBOW ZINC		
46.0mm	C189	G390	SPCC	16 RAINBOW ZINC		
46.0mm	C215	G444	SPCC	16 RAINBOW ZINC		
46.5mm	C209	G420	SPCC	16 RAINBOW ZINC		
47.0mm	C255	G588	SPCC	16 RAINBOW ZINC		
47.5mm	C256	G589	SPCC	16 RAINBOW ZINC		





LENGTH ความยาว	CODE รหัส	ALTERNATE CODE (G) รหัสที่ใช้แทนกันได้	MATERIAL วัสดุ	FINISH สี	DIMENSION (mm) ขนาด (มม.)	
48.2mm	C196	G399	SPCC	16 RAINBOW ZINC		
48.5mm	C40	G060	SPCC	16 RAINBOW ZINC		
48.5mm	C41	G101	SPCC	16 RAINBOW ZINC		
48.5mm	C47	G111	SPCC	16 RAINBOW ZINC		
52.5mm	C56	G123	SPCC	16 RAINBOW ZINC		